

RSM 180/210

Roadside mower



THE ART OF LANDSCAPE MAINTENANCE!

RSM 180/210 ROADSIDE MOWER

RSM 180: simplicity and strength!



Quality of work and compactness are the two main characteristics of this new roadside mower. Suitable for tractors with a power of over 48 kW / 65 hp, the RSM 180 is at ease under extremely varied conditions. The ground following provided by the kinematics with leg will meet every requirement.

Attachment with hydraulic offset

The RSM can be fitted with a hitch frame including a horizontal offset by sliding. This design reduces the overhang and limits forces on the structure during offset manoeuvres. With an offset of 580 mm, going round obstacles is easy and rapid.



You can rely on us

The structure of the chassis and leg are worthy of a KUHN construction: strength and longevity are ensured. In the event of obstacles, the mechanical safety device will protect the machine frame.

- Design with reassembled components,
- Wear rings with cells on all pivot points.

A drive for any conditions

- Housing power 82 hp at 540 min⁻¹;
- 4 high-capacity V-type belts;
- Automatic belt tensioning.



Optimised mowing unit

- Body geometry optimised for optimal output;
- Frame reinforced with bolted sheet metal plate;
- Hardox® steel skids;
- Roller with removable end-pieces Ø160 mm.



Optimal: vertical lifting

- Automatically compensates for uneven ground in addition to the mowing unit's orientation cylinder;
- Can be used to mow at a higher level than the tractor;
- Facilitates shallow ditch mowing while retaining optimal transmission position.

TECHNICAL SPECIFICATIONS

RSM 180

RSM 210

Position of the mowing unit	Side rear	
Horizontal travel range	580 as optional equipment	
Vertical travel range (mm/in.)	600 / 24	
Transport height with 40 cm (m/ft) ground clearance	2.85 / 9'4"	3.15 / 10'3"
Shredding unit safety device	Mechanical	
Max. ditch angle	-55°	
Max. banking angle	+90°	
Machine weight (kg/lbs)	710 / 1565	810 / 1786
Drive speed (min ⁻¹)	540	
Free wheel	integrated in the gearbox	
Transmission	4 V-type belts	
Working width (m/ft)	1.80 / 5'11"	2.10 / 6'89"
Rotor diameter (mm/in.)	425 / 17	
Rotor speed (min ⁻¹)	2210	
Type of tools	Articulated hammer knives	
Number of tools	20	24
Roller diameter (mm/in.)	160 / 6	
Mud flaps	Standard	
Coupling	Cat. 2	
Min. tractor power (kW/hp)	48 / 65	55 / 75
Recommended weight of tractor (t)	3	3,5

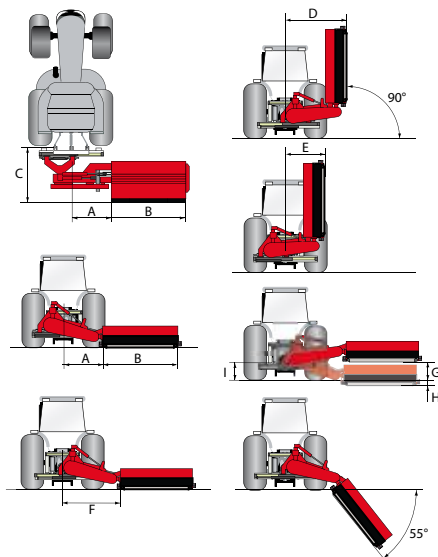

	RSM 180	RSM 210
A	1020 mm	1020 mm
B	1773 mm	2121 mm
C	1205 mm	1205 mm
D	1540 mm	1540 mm
E	960 mm	960 mm
F	1600 mm	1600 mm
G	550 mm	550 mm
H	50 mm	50 mm
I	400 mm	400 mm

Values for machine fitted with hydraulic side offset

Our material is produced in accordance with the European Machinery Directive in the member states of the European Union. In countries outside the E.U., our machinery complies with the safety regulations set by the country concerned. Some safety devices may have been removed from our leaflets in order to clarify the illustration. Under no circumstances should the machine be operated without the necessary safety devices in place (as specified by the assembly instructions and operators manual). We reserve the right to change any designs, specifications or materials listed without further notice. Our models and trademarks are patented in more than one country. Machines and equipment in this leaflet can be covered by at least one patent and/or registered design. Registered trademark(s).

YOUR KUHN DEALER:

KUHN NORTH AMERICA
Corporate Headquarters
1501 West Seventh Avenue - P.O. Box 167
Brodhead, WI 53520-0167 USA
Tel: (608) 897-2131 - Fax: (608) 897-2561
www.kuhnnorthamerica.com

KUHN FARM MACHINERY PTY. LTD
7 Manorwood Pl. - MITCHAM, 3132 VIC,
Fax: 03 9874 3462
www.kuhn.com

United Kingdom :
KUHN FARM MACHINERY (U.K.) LTD
Stafford Park 7,
TELFORD - SHROPSHIRE TF 3 3 BQ
Phone: TELFORD (01952) 239300/1/2
Fax: (01952) 290091
www.kuhn.co.uk



KUHN S.A. - F 67706 Saverne Cedex
www.kuhn.com